

DEPARTMENT OF CIVIL &
ENVIRONMENTAL ENGINEERING
STANFORD UNIVERSITY

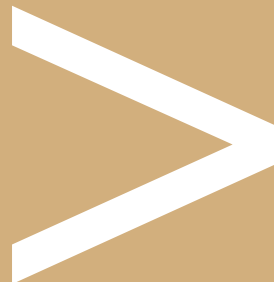

MARCH
2006

MISSION
GOALS
& VISION



Revised March 24, 2006

Mission and Goals	1
The Need for a New Vision	1
A Profession in Transition	2
CEE Departments in Transition	4
Our Vision and Conceptualizations of Sustainability	5
Engineering for Sustainability	6
Embracing Sustainable Engineering	7
Sustainable Built Environment	10
Overview	10
Challenges	11
Opportunities	11
Strengths and Priorities	15
* Stanford Institute for the Built Environment	15
Sustainable Water Environment	16
Overview	16
Challenges	17
Opportunities	17
Strengths and Priorities	19
* Pacific Rim Environmental Research Center	20
* Center for Ocean Solutions	21
Atmosphere and Energy 2	1
Overview	21
Challenges	22
Opportunities	23
Priorities	24
Plan for Faculty Renewal	25

The Department of Civil and Environmental Engineering at Stanford University has a long and rich tradition of excellence in teaching, research, and service. The programs in civil engineering and environmental engineering are ranked among the very top in their fields for which the faculty have received national and international recognition. The department strives to maintain and enhance this position through a continuing process of creating and identifying new opportunities and moving swiftly, but thoughtfully, to bring them to fruition.

Mission and Goals

The primary mission of the department continues to be execution of basic and applied research that advances the state of the profession, the education of the next generation of academic and industry leaders, and the preparation of students for successful careers in professional practice. In addition, the faculty contribute selected service to institutions and government for assessing the technical resources and promoting solutions to meet significant societal problems. In carrying out this mission our goals continue to be

- Providing an education, not just engineering training, by developing life-long skills,
- Contributing to the broader education of Stanford undergraduates,
- Integrating research and education in the graduate and undergraduate curricula,
- Conducting cross-disciplinary research and contributing to, and helping lead, University initiatives,
- Addressing important engineering challenges for well-functioning societies with a new focus on developing research and curricula to promote sustainable civil engineering,
- Maintaining a culture that promotes excellence and that allows students, staff, and faculty to excel in their endeavors.

The Need for a New Vision

Civil and environmental engineers are the engineers who help society to function. In this broad historical context, civil engineers plan, design, construct, maintain, and improve structures, facilities, and other infrastructure, including transportation and energy systems, with the goal of wise and efficient use of resources. In similar historical context, environmental engineers work on methods to protect human health and the environment, including the provision of safe and adequate water supplies, understanding contaminant behavior in engineered and natural systems, and minimizing humankind's impact on the planet's systems and cycles on which all life depends.

Today, at the beginning of the 21st Century, it is evident that the practice of civil and environmental engineering has changed in many ways during the past several decades. Nonetheless, our social contract has not changed. We still



Our thrust in Engineering for Sustainability is exemplified by challenges in the San Francisco Bay Delta. Explosive urban growth in the past 50 years has occurred in a region susceptible to natural hazards, with encroachment on ecologically important estuaries and coastal margins.

create, manage, maintain, and renew society's infrastructure in ways that provide an appropriate quality of life for all, but that also protect, nurture, or renew our fragile environment and natural resources. However, a significant change in the past several decades is that our social contract now must address a common goal of engineering for a sustainable future. The biggest opportunity we face in addressing this challenge is to more fully merge the disciplines of Civil Engineering and Environmental Engineering with the objective of making all of us 'Sustainable Civil Engineers.'

A Profession in Transition

Since their inception more than 150 years ago, the civil and environmental engineering professions have addressed a broad spectrum of societal needs. Historically, the civil engineering profession was concerned with the built environment, including the planning, designing, building, and managing of facilities important for a well-functioning society, while the environmental (sanitary) engineering profession focused on the provision of wholesome and plentiful water supplies and the treatment of wastewaters. Great progress was made throughout the 20th Century towards achieving these goals in the United States and other developed countries. In all of this, a hallmark of the civil and environmental engineering professions was engineering for public benefit.

Now, in the 21st Century, we see some important transitions in the practice of civil and environmental engineering. Our work requires us to deal not just with technical issues and efficient design, but all the more so with the larger social, economic, and environmental aspects of our work. Related to this is the challenge of unprecedented global industrialization and urbanization in developing countries who seek increased wealth and living standards. Some of the issues that lie ahead include the following.

- Engineers must be able to work with and within other cultures. Major design and construction in the world, once dominated by the U.S., is done by international firms and engineers in other nations. Likewise, the problems that we must address will be greater in scale. Regional, national, and international issues are important in how major projects are designed, built, and operated, and in assessing how environmental ef-

facts transcend political boundaries.

- Our civil infrastructure (transportation and lifeline systems) is decaying at an increasing rate. The profession must take the lead in educating the public on how crucial these problems are, and in devising creative solutions.
- Providing adequate supplies of fresh water to the public continues to be a great concern, both domestically and internationally.
- One of the greatest challenges worldwide is protecting the environment and sustaining our future in the face of ever-increasing societal needs and population pressures.
- Energy shortages and impacts of energy use will become more acute. Renewable energy sources and their environmental impacts, and greater attention to energy efficiency, will be major issues in the 21st Century.
- We need new tools for the assessment of the performance and economic rehabilitation of existing structures so that they may be long-lived and continue to serve their function or provide new functions.
- The design and construction processes must be implemented in ways that consider the sustainability of a proposed structure in an integrated and timely fashion.
- The need to move people and goods is constantly increasing. Efficient and ecologically friendly transportation systems must be developed and implemented to serve this need.
- We need better ways to estimate and mitigate risks from natural and human-made disasters – risks that are increasing due to the rapid growth of dense urban regions and mega-cities.
- The education and practice of CEE is likely to see a continual blurring of the division between engineering and science disciplines. Overlap with chemical, mechanical, and materials engineering is common, as well as with the geological, biological, computer, social and management sciences.
- The revolution in information technologies allows us to communicate, teach, access data, and do experiments as never before. Greater flexibility in how, who, and when we teach will impact both the nature of the traditional classroom and the integration of scholarship and learning.



Research on multi-stakeholder conceptual design review with advanced visualization methods informs early design decisions that impact building features and performance based assessments.

These factors suggest that our technical curriculum must recognize that a young person coming to the profession needs breadth, balance, and perspective, something beyond that measured by standardized test scores and grade point average. Successful individuals in the future are likely to be motivated by service, to be skillful at working with different kinds of people, to value different perspectives, and to contribute to consensus building and decision making. Like politicians, civil and environmental engineers must be prepared to deal with an array of issues. Furthermore, civil and environmental engineers should not undervalue their role outside of their area of expertise. Because of their

training and understanding of what makes things work, civil and environmental engineers can and should have a greater influence on issues and decisions that traditionally lie outside of the scope of their professions.

CEE Departments in Transition In the late 1940's and early 1950's, civil engineering undergraduate programs flourished in the United States in response to the need for new infrastructure in the aftermath of roughly two decades of depression and war. The theme of many civil engineering departments at that time was typically "rebuilding America" and it made sense for environmental, structural, geotechnical, construction and transportation engineers to share a common home on university campuses.

Today, the affiliation between the different disciplines that make up a civil and environmental engineering program is less obvious and many civil and environmental engineering departments nationwide are experiencing an identity crisis. Often, sub-programs within civil and environmental engineering departments act more-or-less independently with little interaction.

Rocking Fuse

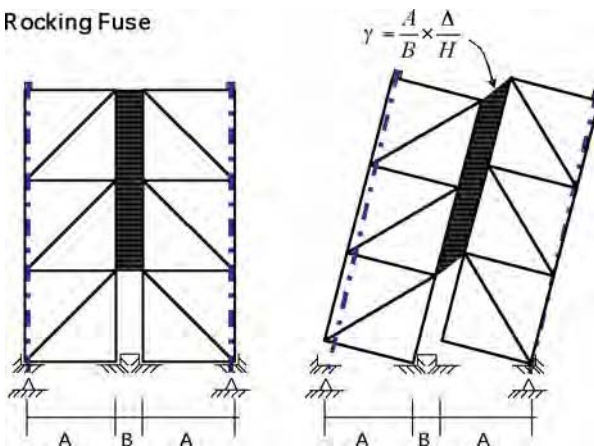

Innovative rocking steel-braced frame with advanced materials will minimize damage from earthquakes. This feature is incorporated in our feasibility design of the High Performance [Green] Dorm.



Civil and environmental engineers can lead the nation in implementing efficient and renewable energy systems. Research in our department examines wind energy technologies and implementation policies, and effects on local climate.

An important question for us and other CEE departments nationally is: "What

(if anything) is the unifying theme of our program?" In other words, how do we maximize our impact? In answering such questions, we must achieve the dual objectives of being more relevant to the current problems and needs of society while refocusing our programs to bring coherency to the department as a whole.

The interdisciplinary nature of the sustainability issues identified above suggests that civil and environmental engineering departments with strong interaction between different research groups within the department and ties to other engineering and science disciplines will be better able to educate future generations of engineers to address

these issues. Our department is pro-active and has a vision that is consistent and supportive with the major, current initiatives of Stanford University— energy and the environment, and international studies. Our department already has strong ties to other engineering and science departments at Stanford University and at other universities around the world. Consequently, we believe that we are in a position to take the lead in educating civil and environmental engineers for the challenges of the 21st Century.

Our Vision and Conceptualizations of Sustainability

The CEE Department must address the modern societal issues identified in the previous section and implement changes that incorporate cutting-edge research and technology into course instruction so that our students are better grounded in fundamentals and our graduating students better prepared for the challenges of today and the future. Our objective is to invigorate our program, and the profession at large, by redefining the practice of civil and environmental engineering for modern society. By doing so, we can ensure that in the future we are not relegated to niche areas, but are leading the way for betterment of all humankind.

As we think about changes, we have identified the following key questions: What will be important in 15-20 years? How do we justify our current and planned faculty composition? What are the foci for our research agendas and curriculum? The answers to these questions are discussed below and are formulated in the widespread agreement among our faculty that the important activities in the 21st Century will include

- sustaining the environment and the natural cycles on which all life depends, and
- providing the necessities for human life and civil societies, including energy, shelter, food, water, and air, and the infrastructure for commerce in more efficient and renewable ways than today.

The theme of “Engineering for Sustainability,” addressing both the natural and built environment and renewable and efficient energy systems, captures these two activities. This theme is greatly leveraged by the university’s initiatives on energy and the environment. We also recognize societal expectations that improvements in the quality of life and economic prosperity must be consistent with mini-



Pathogens in California coastal waters adversely affect people, ecosystems, and local economies. Field studies, laboratory work, and advanced fluid flow modeling identify causes and possible solutions, and improve the scientific basis for public health advisories.

mal impact on the environment and preserving the planet and resources for future generations.

We conceptualize sustainability defined in the context of our department's theme of "Engineering for Sustainability" with respect to three focus areas in which we can have an impact as follows.

Sustainable Built Environment Creating processes, techniques, materials, and sensing technologies for the planning, design, construction and operations of environmentally sensitive, economically efficient, performance-based built systems, and managing associated risks from natural and man-made hazards.

Sustainable Water Environment Creating plans, policies, science-based assessment models and engineered systems to manage water in ways that protect human health, promote human welfare, and provide freshwater and coastal ecosystem services.

Atmosphere and Energy Studying fundamental energy and atmospheric engineering and science, assessing energy-use effects on atmospheric processes and air quality, and analyzing and designing energy-efficient generation and use systems with minimal environmental impact.

Engineering for Sustainability We have adopted "Engineering for Sustainability" as a compelling theme to address the most important problems facing society in the 21st Century. This theme has been effective to unite the department, justify future faculty appointments, gain greater visibility on campus, and invigorate the undergraduate curriculum. This theme bridges our strengths in understanding and managing resource use and impacts on the natural environment and on designing, building, and operating the constructed environment. Our curriculum that embraces sustainable design is forward-looking and naturally fits within civil and environmental engineering. Sustainable engineering design is critical for meeting societal needs in the future as exemplified by the following.

- 20th Century challenges revolved around building our society (e.g. America after the Great Depression and WWII). 21st Century challenges will be in sustaining our societies and building sustainable societies in developing countries
- The 21st Century will see shortages of water, food, shelter, energy, and healthcare. Indeed, future wars might be fought over control of water or energy.
- New technologies and engineering can help limit many of these shortages (policy changes are not



Performance based engineering design of structures considers both safety and the use of buildings after earthquakes to avoid economic loss.

enough). For example CEE can help limit shortages of water and food worldwide through innovative water use/re-use and land-management strategies. CEE can address shelter issues through sustainable design and construction, and energy through efficient use in buildings and by development and effective utilization of distributed renewable energy sources.

- Examples of 21st Century challenges for which civil and environmental engineers may play substantive roles and contribute solutions include:
 - Water shortages for human use (e.g., western and southwestern US), for agriculture (e.g., western US), and inadequate water supply and sanitation (e.g., many parts of the developing world).
 - Decaying quality of natural waters and irreversible impacts on ecosystems (e.g. coral reefs, kelp forests, and estuaries).
 - River, wetland, and estuary restoration and the decommissioning of dams (e.g., San Francisco Bay Region and elsewhere in California).
 - Improving our ability to identify and design-out troublesome chemicals in consumer goods and commercial products before such chemicals become widely used.
 - Improving the predictions for the performance of structures and lifeline (transportation and utility) systems for all aspects of sustainability over their life cycle.
 - Understanding regional and large-scale risks and mitigation against natural and human-made hazards.
 - Recognizing that half of U.S. energy and carbon emissions result from the construction and operation of buildings, which calls for better architectural design and re-directions in the construction industry to eliminate barriers to implementing high-performance buildings.
 - New building design and construction methods that recognize life-cycle costs including sustaining performance following hazards and reconfiguration for long life.
 - Understanding and mitigating unforeseen transaction costs that arise in global projects needed to develop housing and infrastructure for more than a billion new inhabitants of our planet.

Embracing Sustainable Engineering Our department can play a key role in changing CEE practice toward sustainable design and maintenance of the natural and built environment. The complex problems of sustainable engineering cut across all of the sub-disciplines in CEE and bring the department together with a common goal. Addressing these problems effectively requires the unique combination of scientific assessment, engineering design, and management expertise available in the department and at Stanford University.

Due to increasing specialization, CEE departments have tended to evolve into collections of disparate groups held together only loosely by work on infrastructure problems. Sustainable engineering gives us an opportunity to change that view and have a large impact on CEE education and the profession. Our “disparate groups” have important ties that can address the challenges of decreasing and inefficient use of resources, and correcting negative environmental impacts from human activities and population growth.

Under the umbrella of sustainable engineering, a portion of CEE research focuses on large societal problems as opposed to narrower discipline-specific problems while maintaining the depth of expertise in the specific areas. We see opportunities in areas of environmentally - conscious building and infrastructure design, construction, and operation; safer and ecological-friendly materials and products; economical life-cycle assessment and management; efficient water management and supply; better management of anthropogenic impacts and ecosystem protection; and a systems-view of energy efficiency and renewable energy. Examples of CEE-wide challenges include



A field project in San Francisco Bay tests an innovative strategy for in situ treatment of PCB-contaminated sediment that avoids costly and controversial dredging. Such work bridges chemistry, biology, engineering, and policy.

- **Sustainable building design** There are many research questions related to this challenge requiring expertise in: performance-based engineering and design with emphasis on life-cycle assessment metrics; energy conservation and generation during construction and operation; recycled and high-performance materials; minimal site impact and building use recycling; smart sensing and controls; indoor air quality; and design codes and standards for reducing energy use and environmental risks and impacts (e.g., integration of sustainability criteria into architectural and building systems design). Additionally, business, law and policy issues can be included, particularly for types of facilities (e.g., schools, factories, global infrastructure).
- **Sustainable lifeline and infrastructure systems** Planning, assessment and design of distributed transportation and utility systems necessary for modern societies; evaluation of system robustness and management of risks associated with deterioration, natural hazards, accidents, and manmade hazards.
- **Sustainable water use** Energy efficient and low greenhouse-gas-emission treatment systems for water reuse; balancing water for humans versus water for ecosystems, and design of water-wise facilities; and overcoming the barriers to bringing safe water supplies and sanitation to the world's neediest populations.
- **Sustaining coastal waters as resources** The fundamental processes controlling pollution and "brown water" movement; effects of pollution on bathing beaches, coral reefs, kelp forests, and estuary ecosystems; and managing sediments for effective protection of ecosystems and human health.
- **Sustainable product and process design** Environmentally friendly chemicals used in consumer products; environmentally-friendly construction practices including reduced CO₂ emissions from cement manufacture; applying lessons from nature for environmental protection and restoration; recycled materials

for infrastructure, and recycling/reuse of infrastructure itself (e.g. the management of old dams and restoration of storage capacity)

- **Sustainable energy generation and efficient use** – Development of renewable energy sources such as wind and biomass; implementing distributed energy generation systems; energy efficient buildings and coupling building energy systems and vehicle refueling; hydrogen energy generation, storage and use including microbial or catalytic techniques; and energy generation for less developed countries.

To achieve our goals, the department envisions future development and faculty renewal in ways to improve sustainability of the Built Environment, the Water Environment, and Energy Systems and the Atmosphere. The following block-diagram illustrates the proposed educational and research activities to be supported by CEE under the theme of “Engineering for Sustainability.” The themes of our current and proposed programs are shown with linkages among the themes. The new program in Atmosphere and Energy will have strong ties to both the Built Environment and the Water Systems Programs. For example, the new program will link to Built Environment by strengthening programs in green architecture, sustainable construction, and risk management for infrastructure systems. Links to the Water Environment include common interests in environmental biotechnologies and policy, airborne toxins, computational fluid flow modeling, and new kinds of governance for private/public partnerships to develop large-scale water supply infrastructure in developing countries.

The discussions in the following sections elaborate on these three themes according to the following outline: Overview, Challenges, Opportunities, and CEE Program Strengths and Priorities.



The feasibility study for a new, High Performance [Green] Dorm was completed in March 2006. The project team comprised CEE faculty and students; Stanford University staff from Capital Projects, Lands and Buildings, and Housing; and an architectural design team.

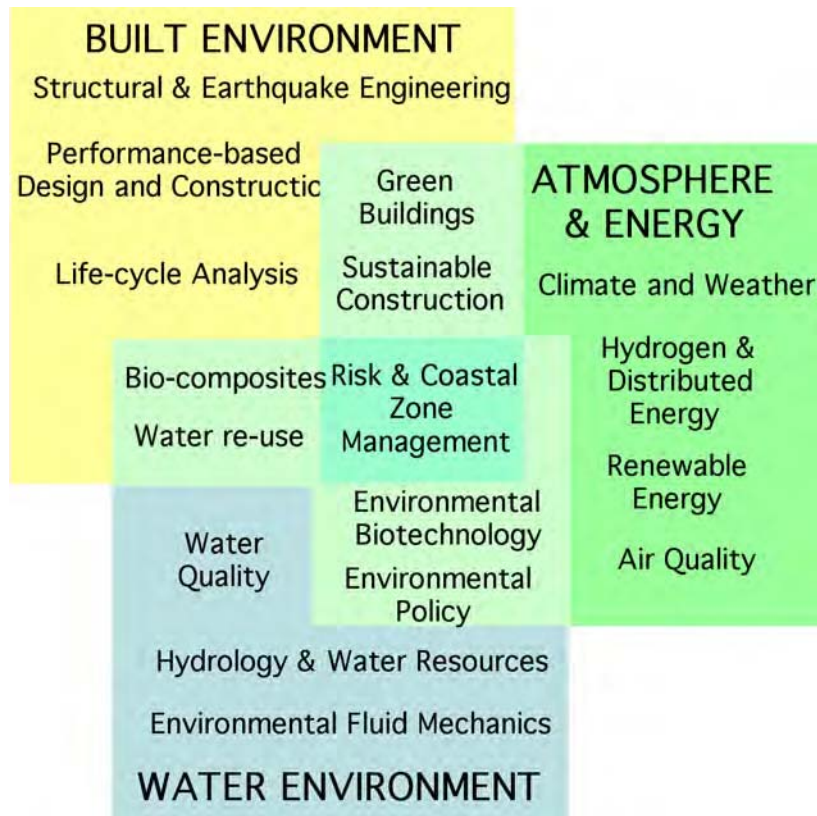

Links among CEE activities related to Engineering for Sustainability

Sustainable Built Environment

Overview

Architecture, Engineering and Construction professionals create the fixed, physical wealth of nations — the “Built Environment” — including residential, commercial and industrial buildings, along with the infrastructure for transportation, water supply, waste treatment, power, health care and communications. The built environment provides the basis for most of the world’s economic and leisure activities. It affects the lives of all humans and impacts the economic performance of corporations and nations.



Our built environment will be sustainable only when its social and environmental context is given rigorous attention at all stages of a project’s life from planning, design and construction to operation, demolition and reuse. We can no longer allow short-term economic savings to override the potential social unrest of introducing new infrastructure with higher long-term fees. We can no longer believe that considering the environment means being mindful of the natural habitat being displaced by a project and yet ignore resource use, emissions and landfill volume resulting from every

project decision. We must improve our fragmented understanding of the interactions between the built environment and its natural, social, and economic contexts.

Stanford University is poised to lead the way in demonstrating how to make and use our built environment in a sustainable and holistic manner. Our innovative research and education practices will produce the technologies, methods and leaders needed to create a truly sustainable, global built environment.

Challenges

The next few decades will witness a rapidly increasing demand to create and renew the built environment in developing and developed countries. Demographers project more than one billion additional inhabitants on our planet over the next decade. Basic housing and infrastructure needs to support this growth have been estimated to cost more than \$20 Trillion. At the same time, developed countries face a multi-trillion dollar backlog of deferred maintenance for their decaying infrastructure and buildings. This unprecedented construction boom will have severe and potentially irreversible impacts on the natural environment and society in general unless our current approach to developing and maintaining the built environment is changed.

The primary challenges to changing our current practices are in: (1) the lack of appropriate materials, systems and sensing technologies necessary for the large scale of infrastructure and building projects to achieve sustainability; (2) the lack of multi-physics models and multi-disciplinary methods to predict the life-cycle performance of infrastructure and facilities; and (3) a lack of tools to implement appropriate design solutions and to unify the fragmented structure of the construction industry.

Opportunities

Opportunities now exist that enable us to develop an integrated performance-based approach necessary to achieve a sustainable built environment. Using our current strengths as well as advancements in other fields, we see three general areas of opportunity: Advanced Technologies, Integrative Analysis Methods, and Avenues of Implementation.

Advanced Technologies: Innovative Sensing, Materials, and Systems

Innovative Sensing Technologies

Finding better ways to instrument the built environment so it can constantly monitor and report its condition will enable new kinds of real-time maintenance, more sustainable operations, and es-



Polymer made from soybean oil can be used in novel structural materials

sential feedback to designers. Recent advances in micro-electro-mechanical sensors, wireless communications devices, wireless networking applications and improved embedded computation tools are facilitating the development of near-real time damage and malfunction monitoring systems that can be useful for performance-based operations. We see opportunities to build on our expertise in sensor network design to develop facility databases and analysis tools to inform sustainable design and operation of future facilities. There are also exciting opportunities to combine sensing and advanced materials development for optimal monitoring of a structures performance over time.

Innovative Materials and Systems

New materials are required to promote and maintain sustainable civil infrastructure systems at the scale our population and societies demand. The materials needed require advancements in two frontiers, one being fundamental development and invention of materials not yet used in the industry and the other being the careful re-engineering of existing materials, both man-made and natural, with a focus on today's and future measures of sustainability. There are numerous opportunities to make these advancements in material design through collaboration with our environmental engineering colleagues as well as through advancements in materials science (e.g. polymer chemistry and ceramics). We can then begin reconfiguring material supply chains and new construction methods to support the initial and continued use of these innovative materials. New materials further create opportunities to engineer and investigate new structural systems, e.g. ones that preserve the economic value of a facility over its life. Both new materials and new sensing technologies open doors to the development of new building energy and thermal systems to improve building operations.

Integrative Methods: The Performance-based Approach

Performance-based approaches offer a new paradigm for our industry – one that is more transparent and scientifically based and where stakeholder requirements and multi-disciplinary decision-making are at the forefront and visible. The primary goals of performance-based approaches are to achieve optimal performance by rigorously considering all stakeholder objectives and by giving systematic evidence as to why we should invest for example, in new materials and building systems. To date, we have developed methods wherein performance is bounded by functional needs, cost effectiveness, and life-safety protection. There are significant opportunities now that can facilitate extending current methods to include the natural and social environment as stakeholders of equal importance.

Performance-based Assessment and Design

The two most compelling incentives for using performance-based assessment and design to address challenges in sustainability are to (1) expedite the implementation of new technologies and materials (e.g. energy-saving build-

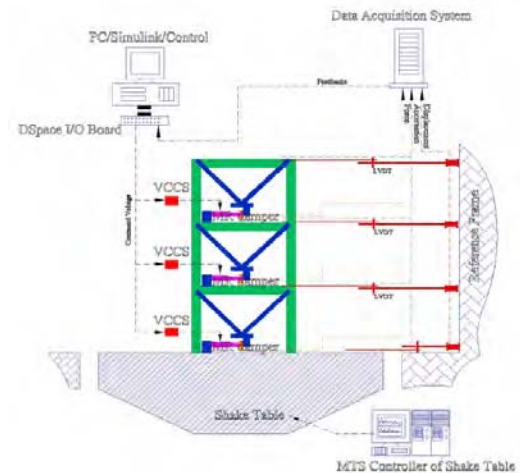

Validation of a wireless monitoring system for assessing building performance

ing systems, fully-recyclable materials, damage-resistant systems), and (2) facilitate interdisciplinary collaboration that will provide solutions meeting multi-faceted social and environmental needs. We have an exciting opportunity to build on the Stanford Blume Center and Center for Integrated Facility Engineering (CIFE) Faculty's core strengths in performance-based earthquake engineering and multidisciplinary modeling to place assessment and design of the built environment more squarely in its social and environmental context through scientific, transparent analyses. With recent advancements in multi-physics and multi-scale computational simulation, we can develop integrative life-cycle cost models (e.g. for energy, durability, indoor air quality, etc.) that will facilitate decision-making where new infrastructure is being built as well as in industrialized countries the trade-offs of maintaining or replacing aging infrastructure must be analyzed.

Performance-Based Construction

Construction of the built environment consumes human and physical resources that can impact their natural and social environments in many ways. Aside from its potential to consume energy and generate significant air, water and ground pollution, construction work has historically had high accident rates, and creates booms and busts in local economies. To improve the construction process, Stanford CEE faculty involved in CIFE have pioneered the development of methods and computational tools to assess the performance of construction organizations and work processes. With these methods, the industry is now designing optimal organizations and work processes to meet project objectives, in the same way that engineers design structures or HVAC systems. The opportunity is to extend our methods and tools to include more social and environmental concerns and embrace and integrate multidisciplinary, multi-stakeholder interests to make the construction phase more sustainable.

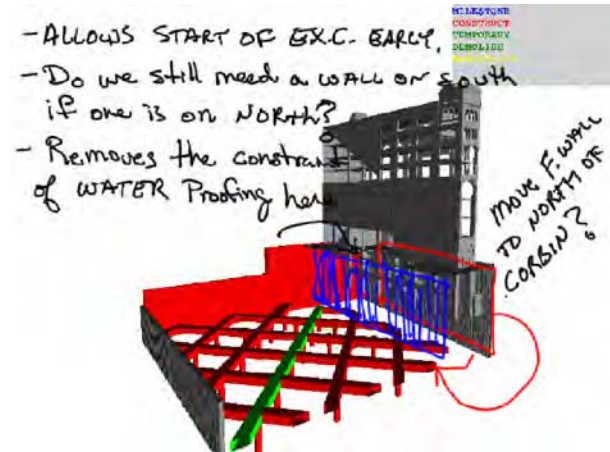

Constructability review with a virtual building model



The new SoE undergraduate program in Architectural Design is administered by CEE in response to student interest and a natural synergy between architecture and civil engineering and related topics in green building design, energy efficiency, etc.

Performance-Based Operations

Over their lifecycle, most facilities incur operating costs equal to several times their design and construction cost. While energy-saving and energy-producing technologies for facilities exist or can be developed, their use is haphazard at best due to a lack of incentives for owners, operators, and users to take a life-cycle perspective. Their performance may also be suboptimal due to lack of attention given to facility users when implemented. We are unlikely to be able to change the incentive mismatch in the short-term. However, with advancements in multi-physics modeling, we see opportunities to develop new modeling and analysis tools that integrate the assessment of building system and building envelope performance in the context of the building's use. We can then begin linking these tools to sensing and monitoring systems to inform better operation protocols and maintenance activities as well as provide feedback to building designers.



Strategic alliances allow CEE researchers to conduct innovative and scholarly research at world-class research facilities. This includes partnerships with unique government laboratories for advanced measurements, modeling, and testing, such as for earthquake resilience as shown here.

Avenues of Implementation: Building Codes and Project Governance Structures

There are several opportunities to facilitate reorganization of the roles and responsibilities of industry participants to align interests toward a lifecycle, sustainable perspective. With our integrative performance-based tools developed and validated, building code guidelines will be able to require lifecycle energy analyses as part of every design review process. Furthermore, using our tools, new lifecycle project governance structures can be developed for stakeholders to communicate and negotiate social and environmental impacts early and throughout a project. Design-Build-Operate-Transfer is one such governance structure wherein a single entity creates, owns and operates the facility for 20 or 30 years. This aligns incentives around long-term sustainability. However these projects are often implemented as private-public partnerships, which are relatively new legal forms; thus, disputes (e.g., about the level of user fees that can be charged) commonly arise during the operations phase, especially in developing countries that do not have a tradition of private ownership and public infrastructure. Stanford's "open intellectual architecture," affords us great opportunities to develop jointly with faculty from the social sciences, law, business, and the Institute for the Environment, the new governance structures we need to make "a sustainable built environment" a reality.

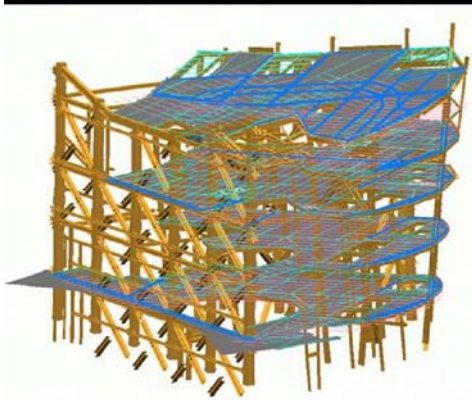

Virtual models of facilities that combine visual, data, and other representations are now an essential tool to integrate multiple stakeholder concerns.

Strengths and Priorities

Our **strengths** are in performance-based assessment and design of structures, risk analysis and probabilistic methods, advanced sensing and materials, computational simulation, and integrated design of facilities, construction processes and organization. All of these areas are vital and central to taking on the challenge of creating and maintaining a sustainable built environment.

Our **priorities** are to hire two new faculty, to channel our research and teaching efforts to a subset of the sustainable built environment challenges, and to secure funding through industrial and institutional support for a Stanford Institute for the Built Environment.

Faculty: Two new faculty are needed who should have expertise in one or more of the following areas: performance-based design and construction, sustainable building energy systems, multi-physics multi-scale computational simulation, innovative construction materials design, advanced sensing and monitoring development.

Focus: We propose to focus our resources and efforts on:

- Sustainable development of individual facilities (i.e. not urban and regional planning).
- Architectural, structural, and mechanical systems of facilities, and their integration.
- Three lifecycle phases: (1) Define and design; (2) Fabricate and Build; and (3) Operate (including maintain, retrofit, reuse and recycle).
- Observing, monitoring and analyzing full-scale projects, including

the proposed new High Performance Dormitory, the new Energy & Environment building.

Stanford Institute for the Built Environment

CEE's research and educational goals regarding the built environment are heavily focused on serving a multi-trillion dollar industry that is vital to the existence of society. This industry is right to be proud of the essential service it provides, but it is also seriously overlooking if not ignoring its opportunities to provide these services in a way that will enhance and not diminish our natural environment. Who can change this? The Stanford Institute for the Built Environment.

Stanford currently has four research centers whose missions vary but all of which address aspects of the sustainable

development of the built environment. They are the Center for Integrated Facility Engineering, the Collaboratory for Research on Global Projects, the Project-Based Learning Laboratory, and the John A. Blume Earthquake Engineering Center. We will bring together these and other CEE faculty, staff and students, along with interested faculty from the Schools of Earth Sciences, Law, Humanities & Sciences, and Business to promote synergy and consolidate expertise in a way that can effectively take on the multi-disciplinary challenges involved in achieving a sustainable built environment. We see great potential to leverage resources from the existing centers and affiliate programs with the Stanford Institute for the Environment whose primary focus is on the natural environment.

The Stanford Institute for the Built Environment will conduct research, educate students and partner with industry and government professionals in four areas of high priority:

- Development of high-risk, high-reward technologies for changing how facilities are built and operated.
- Development of highly integrated analysis, design and visualization tools to support early stage conceptual design of the built environment considering multiple perspectives.
- Enhancing our understanding of cross-cultural and multi-institutional challenges in global projects for the development of new governance structures necessary to implement sustainable practices.
- Identifying and recommending needed changes in local, national and international regulations and policies that will positively affect technical and procedural aspects of the development of the built environment.

Sustainable Water Environment



Billions of people suffer from inadequate water supply and sanitation. Effective solutions require working with local providers and institutions, in addition to new approaches to planning and operations.

Overview

The water environment includes: Coastal zones, rivers, lakes, estuaries, groundwater, soil water, and even the atmosphere as part of the hydrologic cycle. It is now clear that the management of the water environment for sustainable human benefit requires the development of environmental policies promoting ecosystem health and human safety, with accordant management and operation of facilities and systems. Traditionally, civil and environmental engineers have focused on studying parts of the system or designing specific components of an engineered system, such as studying the dilution of effluent achieved through an ocean outfall in order to design an appropriate diffuser. Attention now extends beyond the performance of individual

components, to the performance of whole systems and the interaction of different systems with each other, e.g., the influence of large water project operations on estuarine and coastal fisheries.

Challenges

Economic development and population growth continue to increase the demand for high quality fresh water. However, only a miniscule portion of the global water has quality safe for human consumption and is easily accessible. Fresh water supplies are threatened by both anthropogenic chemicals and pathogens that adversely affect human health and ecosystems and that contribute to declines in fisheries and wildlife. Today over 70,000 synthetic organic chemicals are in use. Many of these find their way into supplies of freshwater and also distress ecosystems.

Particularly affected are coastal areas, where the rates of urbanization and economic growth are the fastest. Growth often takes place in floodplains or marshlands, destroying ecologically valuable habitats while building structures where the risk of inundation during floods or storms is unacceptably high. Local groundwater resources are rapidly mined and the drop in the water table causes land subsidence and seawater intrusion. Existing fresh water supplies are often concentrated away from growth areas, requiring transport of water over long distances. Untreated sewage or environmental spills degrade near-shore marine environments, affect the productivity of fisheries, and can cause illnesses among swimmers.

Opportunities

Opportunities are now available for the development of new technologies to enable more economic treatment of water from lower quality sources (wastewater, brackish, and sea waters). We expect that breakthroughs in material science will lead to a new generation of materials and systems for water treatment. Improved membrane-based processes have high potential in both water reclamation and recycle (RO processes) and in wastewater treatment (e.g., membrane bioreactors), and novel membranes and catalysts will figure prominently in the water treatment systems of the future. RO membrane systems already play an important role in the reclamation of treated wastewater where rejection of organic micro-pollutants such as disinfection by-products, endocrine disruptors, and pharmaceutically active compounds is of great concern. The next generation of membranes and catalysts will facilitate treatment of these contaminants at lower cost and with decreased energy input.



Simultaneous dissolved oxygen and velocity measurements for flow through a barrel sponge in the Florida Keys help CEE researchers model the rate of water processing by sponges. This is key information for understanding nutrient cycling and ecosystem dynamics for Florida reefs.

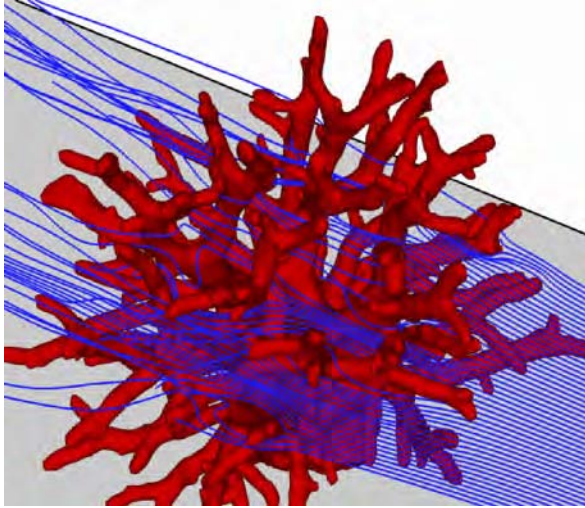

By harnessing high-performance computing technologies we can understand environmental flows and how they affect fragile ecosystems, such as flow and mass transport through coral reefs and kelp forests.

.....

tational technologies, our ability to understand environmental flows and how they affect the water environment depend most heavily on combining process understanding and know-how with modeling and computation, including both software and hardware. We can take advantage of new technologies and maintain a leading role in mathematical modeling of complex environmental processes and systems.

We need to improve our ability to assess the risks presented by chemicals and pathogens in the environment. This means collaborating with toxicologists and physicians, because to enable an estimation of risk, fate and transport models will need to be coupled to models of toxicology and epidemiology. Such models can potentially guide the engineering and management of natural systems, such as a wetland, or the design of new molecules so that human health and environmental problems are avoided (green chemistry). To accomplish these goals, however, we will need to preserve and enhance our abilities to model chemical transport and fate.

To increase the supply of freshwater, we expect that the new reservoirs of the future will be below ground, in aquifers. We have a long and successful track record in this area. That experience has taught us that field-scale experiments are critical for the elucidation of subsurface processes. We have also learned that the knowledge needed for such work is highly specialized and complex. To take advantage of emerging opportunities afforded by the increasing need for aquifers as reservoirs for storage and retrieval of fresh water, we will therefore need to maintain and strengthen our expertise in the execution of large-scale subsurface field experiments.

Regarding the coastal environment, the challenging processes and issues that need to be better understood include the transfer of pollutants into and through the marine food chain [e.g., bridging biological and physicochemical processes and ecotoxicology] and the links between healthy coastal ecosystems and healthy human communities [e.g., pathogens affecting both bathing beaches and marine life]

These problems can benefit from the application of disciplinary expertise found in civil and environmental engineering. For example, in formulating management strategies for protecting California's kelp forests, the use of numerical near-shore circulation and wave models developed for predicting beach erosion can play a critical role in understanding the transport of larval fish and thus be used to locate and design marine reserves. Likewise, models that describe realistically the process of PCB uptake by benthic organisms can lead to more rational and informed sediment management strategies. While all aspects of environmental engineering are becoming increasingly dependent on complex compu-

Given the complex problems we face and the need for efficient and cost-effective strategies, we must address the scientific, engineering, economic, social, and political aspects in an integrated and comprehensive way. We are aware of the value and effectiveness of multidisciplinary teams that may include, for example, experts in social sciences, biology, or fisheries. We will further strengthen collaboration within our department as well as with other departments at Stanford University and elsewhere. Within major research thrusts, such as water supply and treatment, coastal-zone problems, and groundwater, we can develop comprehensive analytical, numerical, and observational tools that enable us to characterize the physical, chemical and microbial environment as well as to translate this knowledge into design principles and management policies.

The significant opportunity presented to our department is the need to apply engineering methodologies to challenging environmental problems through the synthesis of problem identification, analysis, and designing solutions. Although traditionally we have focused on things that have more direct and economic human impact, we increasingly direct our efforts towards the protection of natural systems.

Strengths and Priorities

Our traditional strengths and momentum for our vision of the future lie in four areas:

(1) water treatment and reuse, (2) coastal systems, (3) groundwater, and (4) planning. Our priorities are a new faculty member in Water Quality Engineering and seeking significant funding to support a multi-institution and multi-nation environmental research center.

To capture the opportunities of the future while building on our historical strengths, we have identified at least four faculty needs: (1) a tenure-track faculty member with expertise in process engineering and a focus on chemical transport and fate in natural and engineered systems, (2) a tenure-track faculty member with expertise in process engineering and a focus on the synthesis of new materials and systems for water purification, (3) a research faculty member with expertise in large-scale subsurface field experiments, and (4) a research faculty member in environmental and geophysical fluid dynamics and transport processes, particularly estuarine, near-shore, and coastal flows. We also anticipate that it may be possible to leverage our efforts through interactions with other departments (Material Science and Engineering, Chemical Engineering, Geological and Environmental Sciences) and through the Woods Institute for the Environment. Such leveraging may be especially important for a faculty member with strength in environmental organic chemistry,

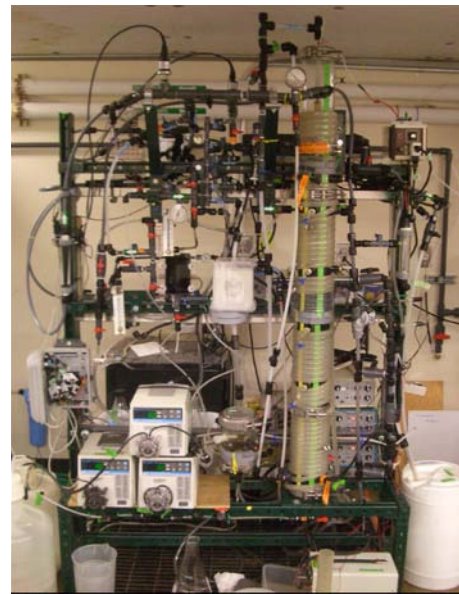

Membrane bioreactors may provide small-scale energy recovery from domestic wastewater and promote water reuse. We plan to test this technology in the proposed High Performance [Green] Dorm

which is important for maintaining excellence in environmental engineering and science.

As a first priority in the near term, we propose a broad area search in the area of water quality process engineering. We would seek an individual with expertise in either chemical transport and fate in natural and engineered systems or new materials and systems for water purification. We also recommend that this search include a research faculty position for an individual with expertise in the management of large subsurface field experiments.

A second priority is to enhance and leverage our educational and research activities in critical domains through leadership in establishing multi-faculty, multi-institution education and research centers. Two initiatives in this area are described below.

A Pacific Rim Environmental Research Center The concept of a Pacific Rim Environmental Research Center is introduced here as an institutional vehicle by which we can effectively marshal and focus the intellectual resources of several research universities on the topics related to freshwater and protection of coastal resources. It will connect experts in the field of water engineering and science, including water and wastewater treatment, water quality, groundwater remediation, membrane technology, photocatalysis, emerging contaminants, and coastal zone protection. Currently, Stanford researchers are actively engaged in numerous environmental programs and collaborations in Asia such as the Singapore Stanford Partnership, Clean Water Programme, State Council of China Executive Leadership Program, and Chair Professors at Tsinghua University, Beijing.

Building on the partnership between the Environmental and Water Studies Program at Stanford University and the Division of Environmental and Water Resources Engineering at Nanyang Technological University (NTU) in Singapore, the PRERC should facilitate the development of collaborative efforts within and between Stanford and NTU, and any other group, department, or institution where significant contribution can be made in the context of the research problem. Such collaborative efforts are currently under way between Stanford, NTU and the National University of Singapore (NUS), and for the Stanford group we envision the joint program providing entrée to the challenging environmental problem set of Southeast Asia and the Pacific Rim. An educational component is already in place through the Singapore-Stanford Partnership, drawing on the graduate environmental engineering programs at NTU and Stanford with the objective of training the next generation of environmental engineering professional leadership of Southeast Asia. For the research component it is necessary to engage the Stanford EWS faculty in joint research projects to get their sustained participation. This effort will include projects that will have components both at NTU and Stanford (including faculty, students, Postdocs and Research Associates). The PRERC concept includes two centers of excellence, one each at NTU and Stanford. The basis for this



Molds and allergens commonly found in the indoor environment effect not only human health but also building use, resale value and insurance liability.

research center has been laid through the beginnings of the SSP PhD and continues through discussions with NTU faculty with long-term support from the Singapore National Science Foundation.

Center for Ocean Solutions A more concerted effort in protecting ocean margins can be achieved by working with the Woods Institute for the Environment to formulate a thrust area within a Center for Ocean Solutions. In the coming decade, we see the integration of ocean sciences and engineering as a major theme for our department, and anticipate focusing on developing analytical, numerical, and observational tools that enable us to characterize the physical, chemical and microbial environment of the coastal zone as well as to work with ocean scientists in translating this knowledge into management policies like marine reserve locations or designs of engineered actions for sediment remediation. We particularly plan on focusing on challenging environments like marshes, estuaries, kelp forests, coral reefs, and the inner shelf.

The Woods Institute for the Environment and the CEE department at Stanford are well positioned to pursue these ventures by teaming with engineers and scientists at the main campus, at the Hopkins Marine Station, the Monterey Bay Aquarium Research Institute, the Monterey Bay Aquarium, and various government laboratories through the USGS or the Corps of Engineers, for example. We have a history of interdisciplinary work with these groups and we are poised to make a significant leap in overall effort and impact. This may be achieved by working with the Woods Institute for the Environment in defining our role in a proposed Center for Ocean Solutions. CEE can contribute key expertise on issues affecting coastal margins, by helping to define critical questions, areas of focus, and collaborative projects. We also can help translate engineering analysis into working solutions and more effective management by working with public and private decision makers. Stemming in part from such discussions over the past year, the Packard Foundation recently provided funding for a planning grant for a proposed Center for Ocean Solutions that would bring relevant parties together into an effective, collaborative community. We see this as a critical opportunity for CEE to address the most significant challenges facing the ocean margins in the 21st Century, and to translate the ideas and information from that and other research into practical solutions to those challenges.



Atmosphere and Energy

Overview

Our vision for a thrust in Atmosphere/Energy encompasses two broad themes: understanding the energy-use effects on atmospheric processes and air quality, and analyzing and designing energy-efficient generation and energy-use systems with minimal environmental impact. Included in this effort is study of emissions on atmospheric chemistry and climate, and development of renewable energy sources such as wind and biomass. In the future we anticipate a much greater emphasis on small-scale, distributed energy generation. Thus, how these systems are implemented, including linking with the existing utility grid, is important in implementing distributed generation systems on a broad

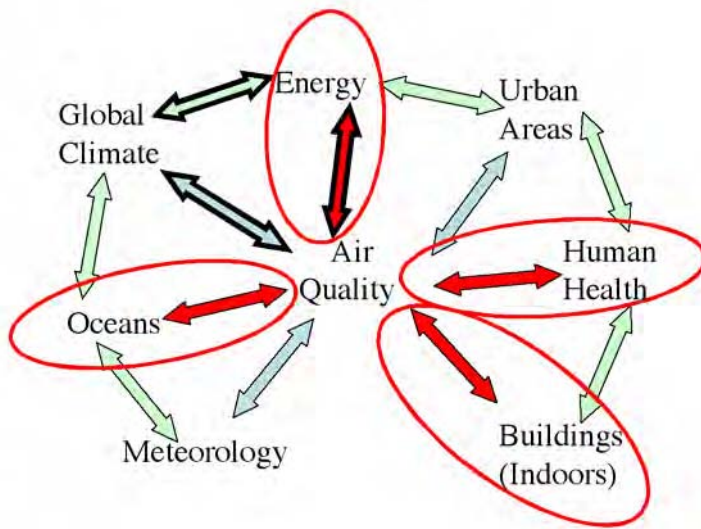

These circles represent key areas in which we see development of research opportunities in atmosphere and energy.

scale. With these objectives, a subprogram in Atmosphere/Energy was created in 2004.

The Atmosphere/Energy (A/E) Subprogram in Civil and Environmental Engineering combines atmospheric science and engineering with energy science and engineering. The main goals are to study fundamental energy and atmospheric engineering and science, assess energy-use effects on atmospheric processes and air quality, and analyze and design energy systems efficiently and with minimal environmental impact. Atmosphere and Energy are linked by the fact that energy use produces emissions to the atmosphere, and the atmosphere feeds back to several energy sources, such as hydroelectric, wind, and solar energy.

As of January 2006, about 60 MS and PhD applications had been received for 2006-7, so we are seeing a rapidly growing level of student interest in this area of study. A/E currently offers an emphasis at the BS and PhD levels, and a transcript designation for the MS degree. Primary faculty include Hildemann, Jacobson, and Tabazadeh, with many other faculty playing important roles in the department or affiliated with the Global Climate and Energy Program and the Woods Institute for the Environment.

Challenges

The primary challenges in Atmosphere/Energy are (1) to ensure that the department has a sufficient number of faculty members with interests in energy to develop research programs and supervise and teach a growing number of students, (2) to address the interests of undergraduate students in A/E topics, and (3) to increase the number of M.S. degree student scholarships to satisfy the growing demand of students for the A/E M.S. degree option.

Faculty with Expertise in Energy The most critical need is to add a faculty member who does research in renewable and efficient energy systems. This person would advise and teach an increasing number of students interested in energy, serving to fill the gap left by an emeritus professor. We are currently conducting a search in area of Renewable and Efficient Energy Systems, Technology, and Policy. Because two other primary energy instructors are not permanent, we also need to consider how to ensure a critical mass in the number of permanent faculty within the

department with interests in energy. Similarly, certain areas of atmospheric studies, such as observational meteorology and cloud microphysics, are not covered in depth in our department but would be valuable for strengthening the A/E program.

Education and Fundraising Because A/E has been a success to date at the graduate level, we should consider how to enhance its accessibility to undergraduates as well. One approach is to create a new unaccredited, pre-approved independently designed undergraduate degree designation through the Department of Civil and Environmental Engineering, a B.S. in Atmosphere/Energy. However, because the School of Engineering is considering an Energy Engineering major and because Earth Science offers an undergraduate energy track, we need to work with these initiatives to avoid repetition. Also, the Department of Petroleum Engineering in the School of Earth Sciences is discussing a reconfiguration of their department on the theme of energy resources. Thus, the landscape on energy education is fairly open at this time. In order to fund the increasing number of MS students in the subprogram, we will seek support either from outside agencies (e.g., NSF IGERT) or donors and consider suggestions for other methods of raising funds for the subprogram.

Opportunities

The core of research activities in the Atmosphere/Energy subprogram may be envisioned as a triangle encompassing air quality, energy, and global climate. In the context of department-wide activities, Atmosphere/Energy research closely interfaces with several related areas: the oceans, meteorology, the built environment, and human health, as illustrated by the figure below:

The circles in the diagram on the previous page highlight the four areas in which we envision key opportunities for developing future research activities and directions over the next 5-10 years.



Smog over Los Angeles, CA. (2000) Photo by Mark Jacobson

1. **Oceans:** Environmental waste has the potential to impact the quality of near coastal waters, and these water quality changes may influence cloud formation and regional climate. One example is the role that phytoplankton blooms may play in regional climate change. Increased discharge of pollutants in coastal waters may cause increases in these blooms, which generate higher concentrations of organic matter near the ocean surface. Wave action then generates airborne droplets that play a role in cloud formation. Increases in the organic content of these droplets may enhance cloud formation and thereby alter precipitation patterns. This links with work on how the deposition of airborne “nutrients” (that is, certain pollutants) from the atmosphere may enhance algal blooms.
2. **Energy:** Once the search for a new faculty member in the area of energy systems/ technologies/policies

is completed, there will be new opportunities for research collaborations between energy and air quality (both on a global and urban level). Research projects are underway in wind energy, as well as the impacts of alternative motor vehicle fuels on both regional pollution levels and global warming.

3. Human Health: The effects of air quality on human health involve both urban-scale and indoor air pollutants, and this area offers rich potential for collaboration across schools. For example, new activities in the School of Medicine that link to the Center for Public Health in the Institute for International Studies can address the socio-economic implications of indoor exposure to pollutants. This is exemplified by collaborations to evaluate human exposure to cooking smoke in Bangladesh both before and after intervention strategies are implemented.

4. Buildings: Faculty and students have been involved for several years in studying indoor air quality and will be offering a new class on this subject for the first time in spring 2006. With the department's new focus on the sustainable built environment and the addition of an architect to our faculty, an obvious avenue for future research is to study the air quality impacts of sustainable building practices, such as the use of recycled materials in the building interior and the utilization of more energy-efficient HVAC systems.

Priorities

The highest priority for longer-term planning from the standpoint of the Atmosphere/Energy subprogram is the need for a critical mass of CEE faculty members with active research interests on the energy side. The single faculty member to be hired within the broad area of Renewable and Efficient Energy Systems, Technology, and Policy will not provide sufficient critical mass in this rapidly growing research area. Thus, we will work with the program in Sustainable Built Environment to hire a CEE faculty member with research interests in the interface between building design and operational energy efficiency. This would establish an important new bridge between programs within the CEE department, as well as focus on a part of the urban environment where great improvements in energy efficiency will be essential in the 21st century.

We should seize any future opportunities that might arise for joint faculty appointments in energy engineering and/or science, especially those that involve areas of energy systems/technologies (e.g., studying the transmission grid and ways to improve it for intermittent renewable energy sources) that are not being addressed by the new faculty member in renewable and efficient energy systems. Likewise, through the Woods Institute for the Environment or the School of Earth Sciences we may seek opportunities for a faculty member with research interests in observational meteorology and/or cloud physics. This faculty member would link to current energy research in our department relating to wind energy and/or hydroelectric power, respectively, as well as strengthen our abilities to study ocean—climate interactions. Multidisciplinary education and research activities in energy are likely to increase significantly at Stanford in coming years, which requires us to engage in campus-wide planning in these areas to remain relevant.



Plan for Faculty Renewal

As described in the preceding sections, our goals for the future envision:

- A more integrated department with linkages across the School and University,
- More of a focus on large societal problems,
- Increased understanding of both the built environment and natural systems, and
- Greater blending of environmental, construction, architectural, and engineering processes.

Our objective is to invigorate our program and the profession by redefining the practice of civil and environmental engineering for modern society. The theme of “Engineering for Sustainability” achieves these goals by focusing our activities on the most important challenges facing society, including preserving the environment and providing the necessities for human life and civil societies. To achieve these objectives, we conceptualize sustainability defined in the context of three focus areas that point us in some new directions and which enhance and leverage our historic strengths: Sustainable Built Environment, Sustainable Water Environment, and Atmosphere and Energy. Our efforts to date are demonstrating success in uniting the department, linking with University initiatives, gaining visibility on campus, appointing new faculty, and invigorating the undergraduate curriculum.

In the near term, over the next three to five years, we may expect three faculty billets to open up due to specific retirement events. In planning for future faculty replacements, we may conservatively assume no net new faculty billets. Within these constraints, the following offers a plan for how we will start gradually reorienting ourselves as department retirements occur, assuming no net growth. Thus, as we look to the future, we see several critical needs for faculty appointments in the built environment, in the water environment, and in energy systems.

In the area of Sustainable Built Environment the critical research challenges are in: (1) appropriate materials, systems and sensing technologies necessary for sustainable large scale infrastructure and building projects; (2) multi-physics models and multi-disciplinary methods to predict the life-cycle performance of infrastructure and facilities; (3) technologies to accelerate innovation in the architecture, engineering and construction industry through more unified planning, design and construction, and (4) technologies for more energy efficient and high performance buildings and infrastructure. Our strengths are in performance-based assessment and design of structures, risk analysis and probabilistic methods, advanced sensing and materials, computational simulation, and integrated design of facilities, construction processes and organization. These areas are central to taking on the challenge of creating and maintaining a sustainable built environment. These needs for the built environment relate to challenges associated with energy management and conservation in the Atmosphere and Energy area, since the construction and operation of the built environment represents a major component of energy use.

Thus in the combined areas of Sustainable Built Systems and Atmosphere and Energy, our priorities are two new faculty members to channel our research and teaching efforts to a subset of the sustainable built environment and

associated energy challenges. We would seek two faculty who have expertise in one or more of the following broad areas: innovative materials, systems and sensing for performance-based design and construction, sustainable and energy efficient building systems including multi-physics multi-scale computational simulation to evaluate and enhance life cycle performance of infrastructure and facilities, and advanced information and computation technologies for design and construction. This will focus our resources on: i) the sustainable development of individual facilities (i.e., not urban and regional planning); ii) the architectural, structural, and mechanical/energy systems of facilities, and their integration; iii) the building lifecycle phases [design, build, and operate including retrofit, reuse and recycle]; and iv) more realistic analysis of complex large-scale infrastructure and building projects.

In the area of Sustainable Water Environment, economic development and population growth continue to increase the demand for high quality fresh water. Economic development and population growth are especially intense near coastal areas, which places evermore stresses on fragile ecosystems. Given the complex problems we face and the need for efficient and cost-effective strategies, we must address the scientific, engineering, economic, social, and political aspects in an integrated and comprehensive way. This requires further strengthening collaborations within our department as well as with other departments at Stanford University and elsewhere. Within major research thrusts, such as water supply and treatment, coastal-zone problems, and groundwater, we can develop comprehensive analytical, numerical, and observational tools to characterize the physical, chemical and microbial environment as well as to translate this knowledge into design principles and workable management policies. As a first priority in the near future to capture these opportunities while building on our historic strengths, we would seek a new faculty member in the broad area of water quality engineering. We would seek an individual with expertise in either chemical transport and fate in natural and engineered systems or new materials and systems for water purification.

Our vision for a thrust in Atmosphere and Energy encompasses two broad themes: understanding the energy-use effects on atmospheric processes and air quality, and analyzing and designing energy-efficient generation and energy-use systems with minimal environmental impact. The primary challenge in the Atmosphere and Energy area is to ensure the department has faculty with primary research in energy use efficiency and renewable energy systems. We currently are conducting a search in the area of Renewable and Efficient Energy Systems, Technology, and Policy. We will continue the search into the foreseeable future. Also, as described above, since about half the energy use in the United States is associated with the creation and operation of constructed facilities, the appointment of a faculty member in Sustainable Built Environment with expertise on building life cycle performance and energy use further strengthens the thrust in Atmosphere and Energy.

In addition to these needs, we describe in this document strategic areas for appointment of research professors or faculty with joint appointments. In the area of research professors, we may seek one with expertise in integrated facilities engineering and another with experience in the management of large subsurface field experiments. We also point to opportunities for joint faculty appointments that fit within our overall mission and goals. Some examples include environmental organic chemistry, energy systems and technologies, and meteorology.